

Wrapman

POWER PRE-STRETCH 100%

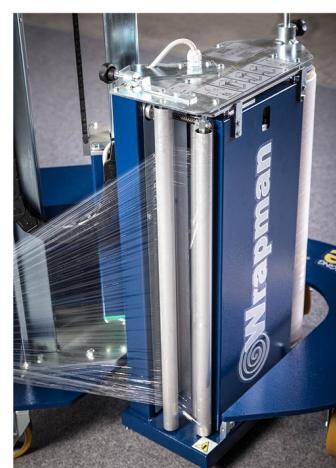
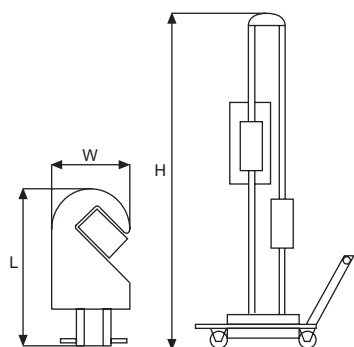
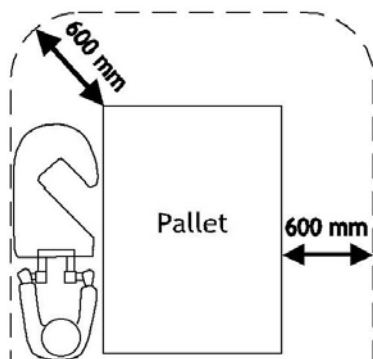
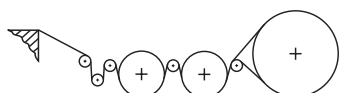

MODELS	max useful pallet height	H (mm)	L (mm)	W (mm)	weight	autonomy	max diameter film coil	core types of film coil
WRAPMAN 2.0	2.0	2110	1015	570	121 kg	70 pallet	145mm	50-76 mm